

## Isolated Barrier

GS8531-EX  
GS8532-EX

GYB14.1636



Please read the instruction manual carefully before use the product, and please safekeeping.

### ⚠ Caution

- Please check whether the product type on the package accords to the ordering contract;
- Read this manual carefully before installation or using. If there is anything unclear, please dial technic support hotline-400 881 0780;
- Isolated barrier should be located in the safe area;
- Supply voltage is 24VDC, 220VAC is forbidden;
- Users are not allowed to dismantle or repair the barrier otherwise it will induce malfunction.

### ■ Connections

- (1). This barrier adopts knock-down connector with screw terminals. The intrinsically safe (IS for short) terminals (blue plugs) should be connected to hazardous area devices and the non-IS ones (green plugs) to the safe area devices.
- (2). Choose for the hazardous area the blue-marked wires. Its minimum cross section area should be 0.5 mm<sup>2</sup>, and minimum dielectric strength should be 500V.
- (3). The wirings in safe area and hazardous area must be separated, and both have protection bushes.
- (4). A length of 8mm bared wire is locked by the M3 bolt. See as shown below.

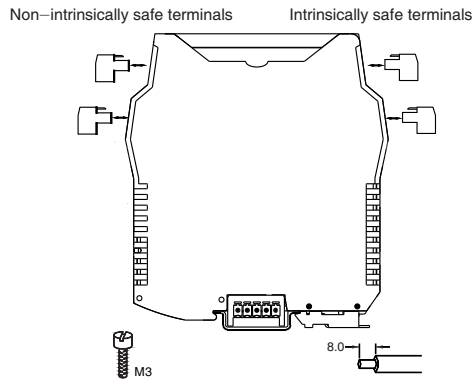

### ■ Disassembly

- (1). Insert a screwdriver (its edge length ≤ 6mm) into the downside metal lock of the barrier;
- (2). Push the screwdriver upwards, then prize the metal lock downwards;
- (3). Take the barrier out of the guide rail.

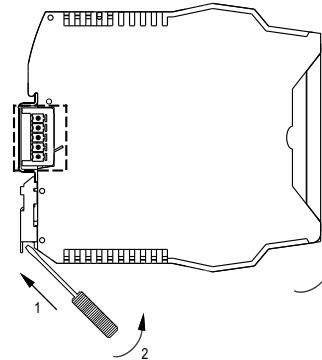

### ■ Installation

During installation, operation and maintenance, users shall comply with the relevant requirements in GB 50257, GB 3836.13, GB 3836.15 and GB 3836.16.

GS8500-EX series isolated barrier are designed for mounting on 35mm DIN guide rail.

Installation according to the following steps:

- (1). First make the bus-powered outlet locked into the guide rail; (If no bus-powered function, omit this step);
- (2). Make the upside of the barrier locked into the guide rail;
- (3). Push the downside of the barrier in the rail.

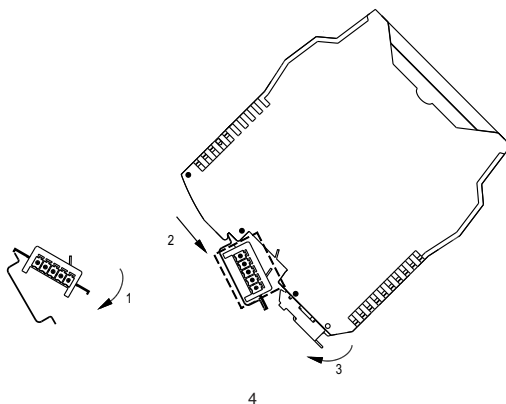

### ■ Maintenance

- (1). Before using, please check again whether the module's Ex-proof rating accords to the operation conditions, and also wiring and polarity are correct.
- (2). It is disallowable to test insulativity among the terminals with a megameter. If necessary, the wires must be cut off before testing, or the internal fuse would blow.
- (3). Every product has been test strictly before leaving factory. If users find any abnormality in the module, please contact the nearest agent or our company.
- (4). In 5 years from the delivery date, if the product works improperly during normal operation, we will repair or replace it without payment.



SHANGHAI CHENZHU INSTRUMENT CO.,LTD.

Add: Building 6, 201 Minyi Road, Caohejing Hi-Tech Park  
Songjiang New Industrial Park, Shanghai 201612, P.R. China  
Tel : +86-21-64513350 Fax : +86-21-64846984  
Email : chenzhu@chenzhu-inst.com  
<http://www.chenzhu-inst.com>

## Summarize

Analogue input, output isolated barrier. It can provide the transmitter located in the hazardous area a separate power, transfer current signal generated by transmitter from a hazardous area to a safe area, can also transfer current signal from a safe area to a hazardous area and drive equipments like actuator in field. It allows bi-directional transmission of HART communication signals, and is suitable for using loop-powered DCS, PLC systems.

## Specification

**Number of channels:** 1(GS8531-EX)  
2(GS8532-EX)

**Application 1:**  
**Supply voltage(Ue):** 20~30V DC

**Safe-area output:**

Current: 4~20mA, HART digital signal  
HART communication, load resistance:  $R_L \geq 250\Omega$

**Hazardous-area input:**

Current: 4~20mA, HART digital signal  
Available voltage:  $U_o \geq U_e - R_L \times 0.02-6$

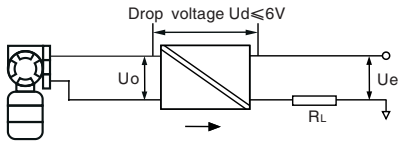

**Transfer accuracy:** 0.4%F.S.

**Application 2:**

**Safe-area input:**

Current: 4~20mA, HART digital signal

**Hazardous-area output:**

Current: 4~20mA, HART digital signal  
Load ability:  $R_L \leq (U_i - 6)/0.02$   
HART communication, load resistance:  $R_L \geq 250\Omega$

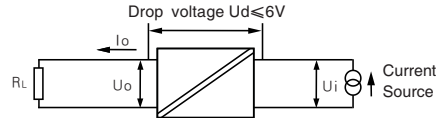

**Transfer accuracy:** 0.2%F.S.

**Temperature drift:** 0.01%F.S./°C

**Power supply protection:** Protect the barrier from reverse supply voltage destroy

**Electromagnetic compatibility:** According to IEC 61326-1(GB/T 18268)  
IEC 61326-3-1

**Dielectric strength:**

Between non-intrinsically safe part and intrinsically safe part  $\geq 2500VAC$

**Insulation resistance:**

Between non-intrinsically safe part and intrinsically safe part  $\geq 100M\Omega$

**Weight:** Approx.150g

**Suitable location:** Mounting in non-hazardous area, and connected to the IS apparatus in zone 1 hazardous area.

**Suitable IS apparatus:**

Application1:

2-wire intelligent transmitter(HART), 2-wire intelligent transmitter

Application 2:

2-wire valve positioner, electrical converter

## Operation Conditions

(1). The air should not contain any medium corrupting the coat of chrome,nickel and silver.Moreover,violent quiver and impact or any cause of electromagnetic induction (such as big current or spark,etc.)must be avoided when using.

(2). Operating temperature: -20°C~+60°C

(3). Storage temperature: -40°C~+80°C

(4). Relative humidity: 10%~90%

## Intrinsic safety description

**National Supervision and Inspection Center for Explosion Protection and Safety of Instrumentation(NEPSI)**

**Compliance with standard:**GB3836.1, GB3836.4 and GB3836.20

**Ex-marking:** [Ex ib Gb] IIC

**maximum voltage:**  $U_m = 250V$

**Intrinsic safety parameter:**(7,8 ;9,10 terminals)

$U_o = 23.1V$ ,  $I_o = 29mA$ ,  $P_o = 670mW$

IIC :  $C_o = 0.096\mu F$ ,  $L_o = 0.5mH$

IIB :  $C_o = 0.288\mu F$ ,  $L_o = 1.5mH$

IIA :  $C_o = 0.528\mu F$ ,  $L_o = 4.0mH$

Largest external capacitance ( $C_o$ ) and inductance ( $L_o$ ) numerical attention when using the following requirements:

(1) For distributed inductance and capacitance e.g. as in a cable, allow the values of capacitance and inductance;

(2) For circuits containing up to 1 % inductance or up to 1 % capacitance with a cable, allow the values of capacitance and inductance;

(3) For connection of the combined inductance and capacitance where both are greater than 1% of the allowed value (excluding the cable), allow up to 50% each of the values of capacitance and inductance.

## Intrinsic safety explosion protection loop system

Special requirements have to be confirmed before using the intrinsically safe explosion loop system(intrinsically circuit) which connected by isolated barrier and intrinsically safe apparatus in field:

(1) The explosion level of intrinsically safe apparatus should meet the requirements of operation conditions. The apparatus should pass the explosion protection test and get the certificate by state-authorized explosion-proof product certification bodies.

(2) The intrinsic safety parameters of isolated barrier and intrinsically safe apparatus both are sure, and comply with 12.2.5 of GB 3836.15-2000.

(3)If any parameters are unclear, the system has to be confirmed by state-authorized explosion-proof product certification bodies.

## Application

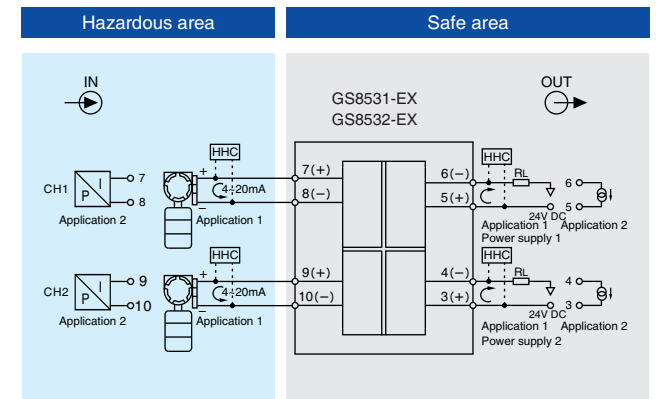

Note:

- 1.GS8531-EX only contains CH1;
- 2.Can't use HHC (HART operator) in hazardous area and safe area at the same time;
- 3.HHC (HART operator) used in the hazardous area must get the explosion proof certification.

## Dimensions

118.9mm×106.0mm×12.5mm

